

V1.0



Using a 32-bit motor driver chip and Field-Oriented Control (FOC), the RoboMaster C620 Brushless DC Motor Speed Controller enables precise control over motor torque.

Exclusively designed for the RoboMaster M3508 P19 Brushless DC Gear Motor and C620 Brushless DC Motor Speed Controller, this M3508 Accessories Kit includes several cables and a terminal board.

Refer to System Specification Manual, RoboMaster User Manual, Introductions of RoboMaster System Module.

The M3508 Accessories Kit includes several cables and a terminal board, please refer to the introduction of the accessories.

ROBOMASTER 2022 UNIVERSITY Sim2Real CHALLENGE

RULES MANUAL

RoboMaster Organizing Committee
Released on February 2022

Statement

The RoboMaster Organizing Committee (hereinafter referred to as “the RMOC”) encourages and advocates for technological innovation, open-source technology, and respects the intellectual property of participating teams. All rights related to the intellectual property developed during the competition are owned by the individual teams. The RMOC will not be involved in the handling of intellectual property disputes within teams. The participating teams must properly handle all aspects of intellectual property rights among internal school members, company members and other members of the team.

While using the supporting materials provided by the RMOC, teams should respect the owners of all intellectual property. Teams are also prohibited from engaging in any behavior that violates intellectual property rights, including but not limited to reverse engineering, replication or translation.

With regard to any behavior that may infringe upon the intellectual property rights relating to educational materials provided for the competition by the RMOC or co-organizers, the intellectual property rights owners are entitled to hold the infringing parties responsible in accordance with law.

Release Notes

Date	Version	Changes
February 14, 2022	V1.0	First release

Table of Contents

Statement.....	2
Release Notes	2
1. Introduction	7
2. Competition Area.....	7
2.1 Overview	7
2.2 Starting Zone.....	9
2.3 Exchange Station	9
2.4 Mineral Zones	11
2.5 Minerals.....	11
3. Simulation Technology Architecture	12
3.1 Simulation Platform	12
3.2 Data Interface.....	12
3.3 Platform Architecture.....	13
4. Competition Mechanism.....	13
4.1 Exchange Markers Mechanism	14
4.2 Rules on Exchanges	14
4.3 Scoring	16
5. Competition Process.....	17
5.1 Simulator Test	17
5.2 Sim2Real Test	17
5.3 Formal Match.....	18
6. Season Schedule	19
7. Participation	19
7.1 Participating Teams	20
7.2 Team Member	20
7.3 Other Requirements	21
8. Awards.....	22

9.	Appeals	23
9.1	Appeal Materials	23
9.2	Appeal Process	23
9.3	Appeal Decision	24
10.	Q&A	24

Tables Directory

Table 4-1 Ranking example	16
Table 5-1 Competition Flow	18
Table 6-1 Season Schedule	19
Table 7-1 Team Member' roles and responsibilities	20
Table 7-2 Roles and responsibilities of regular members.....	21
Table 8-1 Awards Setup.....	22

Figures Directory

Figure 1-1 RoboMaster EP	7
Figure 2-1 Site modules	8
Figure 2-2 Site axonometric view	8
Figure 2-3 EVA mat	9
Figure 2-4 Starting Zone	9
Figure 2-5 Exchange Station.....	10
Figure 2-6 Receptacle dimensions	11
Figure 2-7 Mineral Zones.....	11
Figure 2-8 Mineral.....	12
Figure 4-1 Exchange successful	15
Figure 4-2 Exchange failed.....	15
Figure 4-3 Exchange failed.....	15
Figure 4-4 Exception	16

1. Introduction

The RoboMaster University Sim2Real Challenge (“Sim2Real”) at its core allows participants to win points by rearranging minerals using fully automated RoboMaster EPs that have been modified officially. The match lasts for five minutes with a sim2real-based format, where robots rearrange minerals based on the information shown on the exchange tags to earn points. Participants will be ranked according to their total points won. The objective of the challenge is to assess how well a program completed on a simulation platform can be operated in real application environments. Teams are required to develop and debug their algorithms in a simulator and submit their codes by the specified deadline. The official staff will deploy corresponding codes in physical robots of the same models to rearrange minerals. Compared to other RoboMaster University events, this challenge does not require teams to build physical robots, allowing participants to focus entirely on algorithm design.

Figure 1-1 RoboMaster EP



2. Competition Area



The error margin for the dimensions of all Competition Area and Components described in the document is $\pm 5\%$. The unit for the size parameters on the site drawings is mm.

2.1 Overview

The competition area is a 4*5m rectangle consisting of infrastructures such as Starting Zone, Exchange Station, Mineral Zones, Obstacle Block, and Road, as shown below.



The labels for Mineral Zones below only indicate their general areas and do not represent their specific locations on-site.

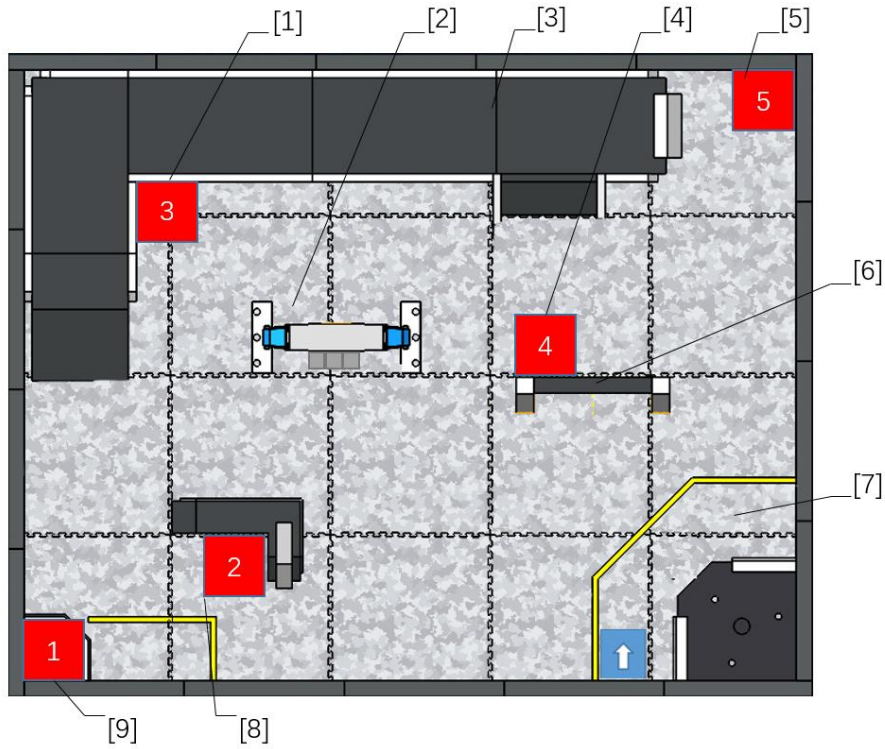

- [1, 4, 5, 8, 9] Mineral Zones
- [2] Exchange Station
- [3] Road
- [6] Obstacle Block
- [7] Starting Zone

Figure 2-1 Site modules

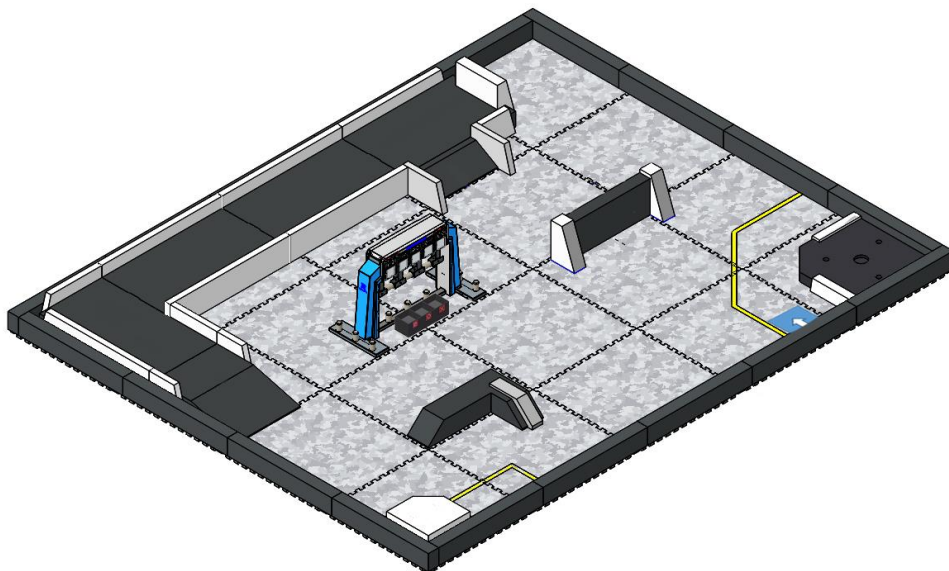

Figure 2-2 Site axonometric view

The floor is covered by 20mm-thick EVA mats. The Road and other modules on the site are also made of EVA.



Figure 2-3 EVA mat

2.2 Starting Zone

The Starting Zone is where robots are placed before a match starts. A robot is placed in the blue square area with a special positioning frame at the start of the match. The robot's gripper must face the same direction as the arrow.

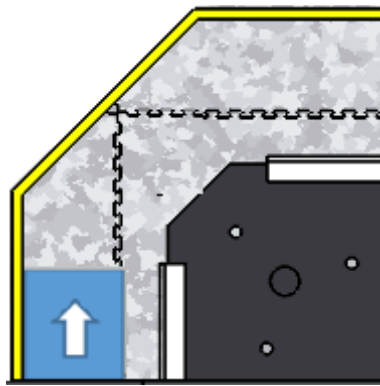
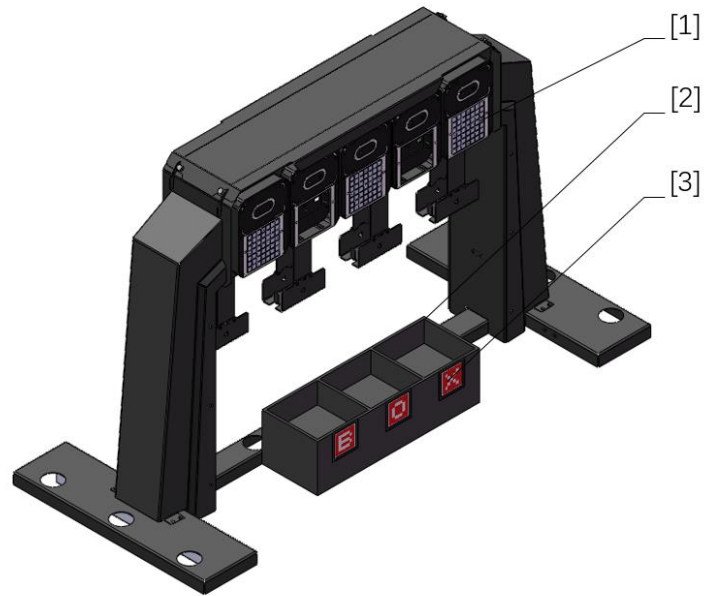
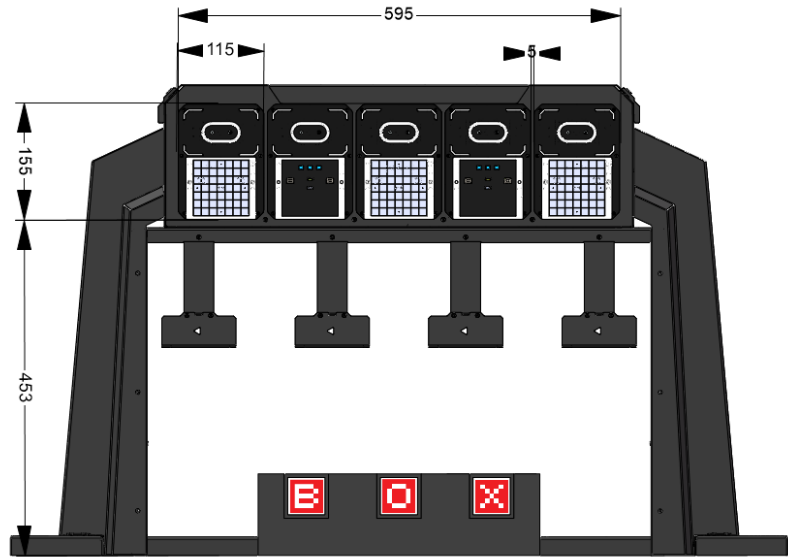

Figure 2-4 Starting Zone

2.3 Exchange Station

An Exchange Station is made up of three exchange markers and a receptacle.

The three markers are above the receptacle, which has three slots each corresponding to a marker above. A localization marker can be found on the front of each slot to facilitate localization by robots.



- | | | | | | |
|-----|--------------------|-----|------------|-----|------------------------|
| [1] | Exchange
marker | [2] | Receptacle | [3] | Localization
marker |
|-----|--------------------|-----|------------|-----|------------------------|

Figure 2-5 Exchange Station

The dimensions of the receptacle are as shown below (in mm):

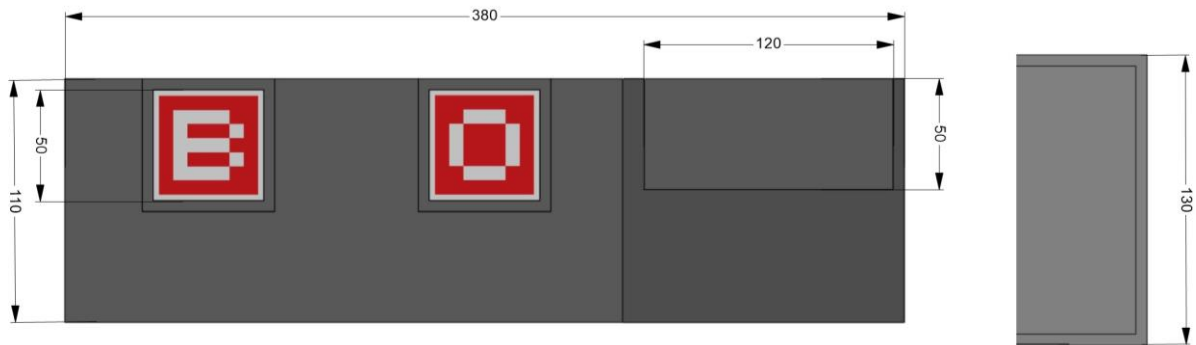

Figure 2-6 Receptacle dimensions

2.4 Mineral Zones

A total of five Mineral Zones are set up in the Competition Area as shown below.

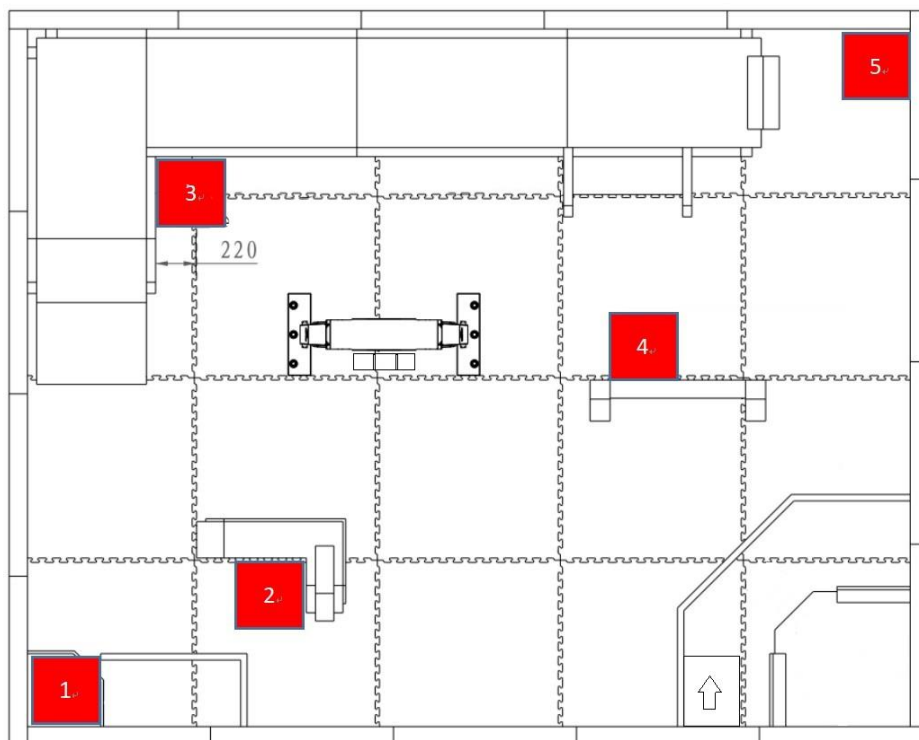

Figure 2-7 Mineral Zones

2.5 Minerals

A mineral is an ABS cube with an edge length of 45 mm and weight of about 98 g. Each cube has the same number identification tag on all sides against a red background. The numbers range from 1 to 5 for different cubes.

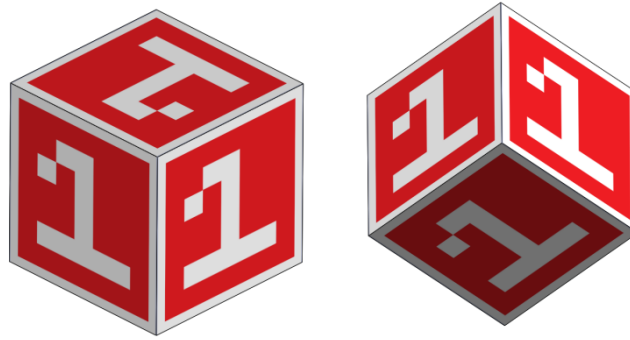

Figure 2-8 Mineral

3. Simulation Technology Architecture

3.1 Simulation Platform

The simulation platform used for the challenge is AI Habitat 2.0. The platform is mainly comprised of two components: Habitat Sim and Habitat Lab. Habitat Sim is a high-performance physics-enabled 3D simulator, while Habitat Lab is a modular library for end-to-end training tasks.

3.2 Data Interface

The standard communication interface used in the challenge is ROS, which bridges the AI Habitat platform with existing robotics resources via ROS-X-Habitat. The RMOC will provide standardized sensor data sampling interface and actuator control interface for the robots, so teams only need to focus on the development of their robotic algorithms. For more details on the sensor data and other parameters provided by the robots, please refer to the officially released “Tutorial” file.

3.3 Platform Architecture

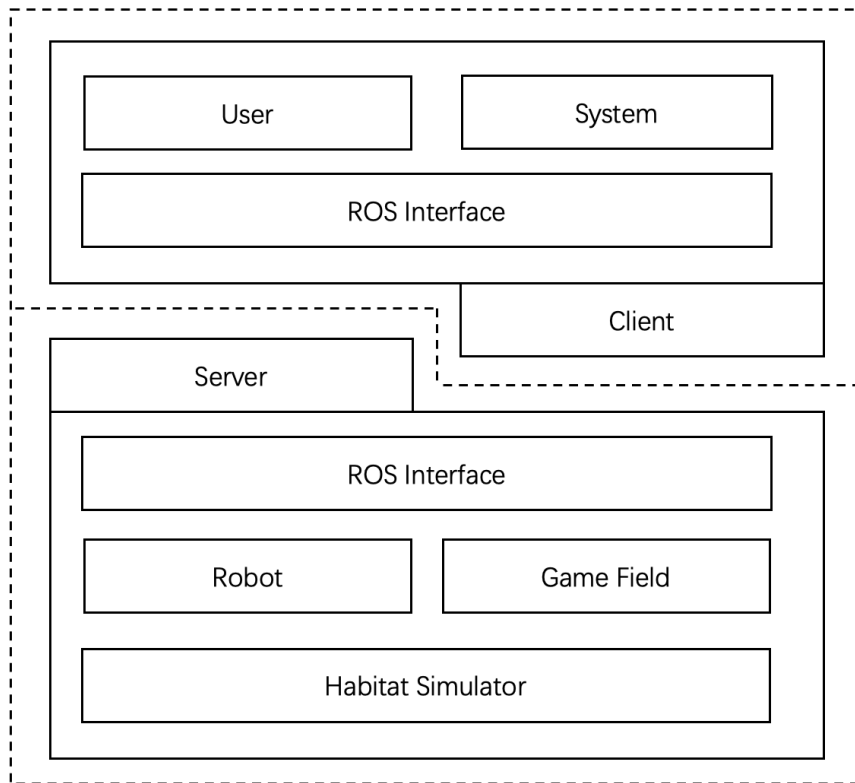

Figure 3-1 Platform architecture

The simulation architecture consists of two components: the Server and the Client.

The Server is a Docker image for the Habitat preconfigured by the RMOC. In a simulated environment, the Server will provide robot models and the competition site to the team. The Game Field Module includes: the Competition Area, Exchange Station, Minerals, and other equipment. The Robot Module consists of: the sensor data sampling interface and actuator control interface. For specific descriptions of the interface, please refer to the officially released “Tutorial” file.

The Client is a Docker image simulating hardware resource of the main controller of the RoboMaster EP robot, and serves as an independently packaged Docker image for the challenge mission. Teams can call the interface provided by the Server image and develop algorithms for the challenge mission in the Client image. The User Module consists of: the Demo program provided by the RMOC and the functional modules required to be developed by the teams. The System Module consists of: the monitoring and log systems for all challenge missions, and the communication functions for the referee system. The System Module has a higher process priority than the User Module.

4. Competition Mechanism

Each round is limited to 5 minutes. After the start of a match, the official staff will place a mineral with the corresponding number in each Mineral Zone on the site. After departing from the Starting Zone, the robot will have

to pick up the minerals from the Mineral Zones automatically and place them in the correct receptacles according to the exchange markers. The competition ends when the team successfully exchanges three minerals or the match time elapses. If the referee stops the match (due to unexpected incidents with a robot not attributable to the organizer) or a team member requests to stop the match, the team will forfeit its challenge opportunity with no results recorded for the current round.



A robot is only allowed to carry one mineral each time. Any violation will result in the immediate termination of the match.

4.1 Exchange Markers Mechanism

At the start of a match, the exchange markers will show three different randomized digits from 1 to 5. The numbers will remain unchanged throughout the match. To earn points, the robot is required to place minerals in the correct receptacles by matching the number tags on the minerals with the numbers on the exchange markers.

4.2 Rules on Exchanges

A mineral is only deemed exchanged when the following conditions are satisfied:

1. The robot places the mineral into the receptacle whose exchange marker corresponds to the mineral's number tag (in no particular sequence);
2. Any side of the mineral is in full contact with the bottom of the receptacle.



If two or more minerals have been dropped in a receptacle, the points will be calculated based on the first placed mineral.

The following are illustrations of different exchange statuses:

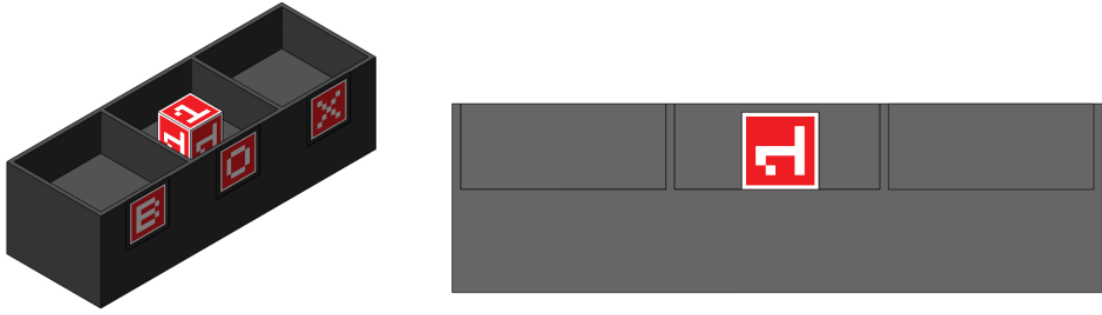

Figure 4-1 Exchange successful

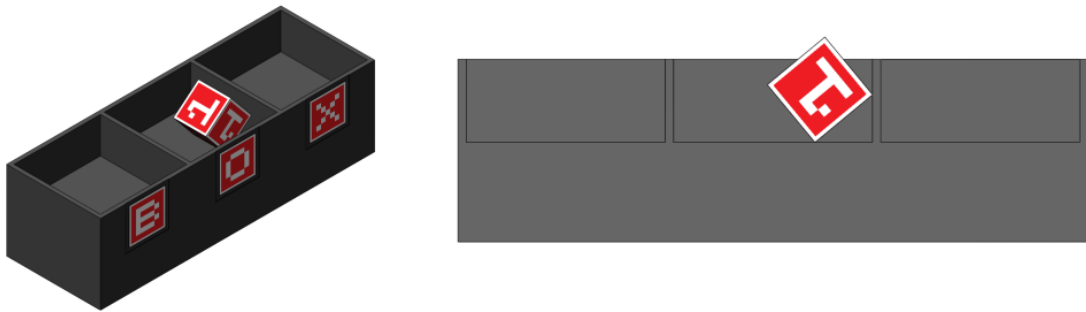

Figure 4-2 Exchange failed

(None of the mineral's sides are in full contact with the bottom of the receptacle)

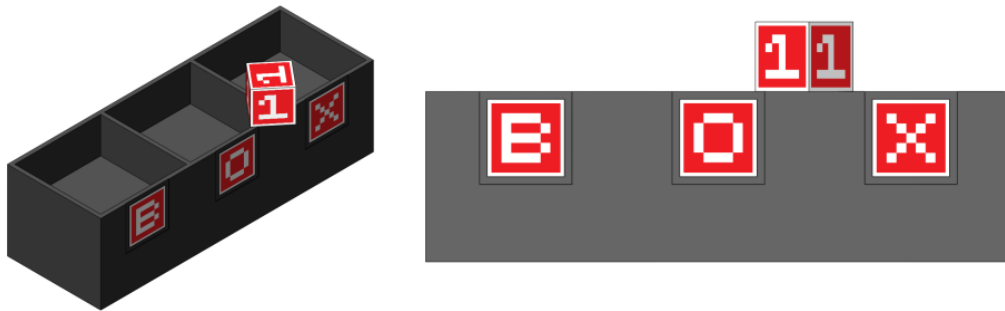

Figure 4-3 Exchange failed

(The mineral is not in any of the receptacles)

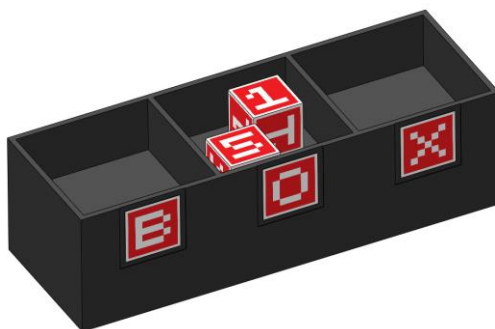

Figure 4-4 Exception

(The exchange is deemed successful if the first placed mineral satisfies the conditions for a successful exchange)

4.3 Scoring

The points shall first be calculated based on the number of minerals successfully exchanged. If the quantities of minerals exchanged are the same between two or more teams, they will be ranked by their time spent to complete the exchanges. The team with the shorter exchange duration will rank higher.



Exchange duration: The time spent to complete all successful mineral exchanges in a round (precise to 0.1 s).

Teams will be ranked based on the following rules:

R1: Teams are ranked by their highest score from the three rounds;

R2: Teams with the same highest scores will be ranked by their second highest scores, so on and so forth;

R3: Any two or more teams with the same scores across the three rounds will compete again in a rematch. The results of the rematch will only be used to rank the teams with the same scores and will not be considered for the final ranking.

Table 4-1 Ranking example

Ranking	Participating Teams	Highest score		Second highest score		Lowest score	
		No. of minerals exchanged	Exchange duration	No. of minerals exchanged	Exchange duration	No. of minerals exchanged	Exchange duration
1	S	3	239.4	3	246.8	3	249.9
2	E	3	254.5	3	263.1	2	232.1
3	X	3	254.5	3	272.8	2	254.1

Ranking	Participating Teams	Highest score		Second highest score		Lowest score	
		No. of minerals exchanged	Exchange duration	No. of minerals exchanged	Exchange duration	No. of minerals exchanged	Exchange duration
4	Y	2	209.2	2	265.5	1	201.8
5	A	2	263.4	1	232.4	1	254.9
6	I	1	227.3	1	269.4	0	300

5. Competition Process

The challenge is made up of three stages: Simulator Test, Sim2Real Test, and Formal Match.

5.1 Simulator Test

The Simulator Test lasts from March 1 to March 30. During this stage, teams will focus on developing algorithms in a simulated environment and completing the challenge mission, which consists of the following:

1. Downloading the Docker images for the Habitat and challenge mission from the official website.
2. Configuring the local environment based on the official “Tutorial” file, running the Demo program, obtaining the robot’s sensor data, and controlling the movement and grabbing mechanism of the robot.
3. Completing the mission algorithms according to the competition rules and submitting the codes to the portal designated by the RMOC.
4. On March 31, the RMOC will conduct the Technical Assessment and shortlist the qualified teams for the next stage.

5.2 Sim2Real Test

The Sim2Real Test lasts from April 1 to May 15. During this stage, qualified teams will debug and optimize their algorithms using the test data from the real physical site. The processes are as follows:

1. Teams submit their codes to the portal designated by the RMOC.
2. The RMOC will deploy and run their codes on RoboMaster EP robots, to execute the challenge mission on the real competition site.
3. The robot’s feedback data and test match video will be uploaded by the RMOC on a designated platform for teams to download.

4. The teams will optimize their algorithms based on the feedback data and match video.

During this stage, the teams will repeat the four steps above, and continue requesting for on-site tests and adjusting and optimizing their algorithms.



Each week’s on-site tests are subject to limited time slots. The schedule will be announced on the official submission webpage. Teams are advised to plan their time accordingly. The final date for teams to submit their codes is May 20.

5.3 Formal Match

The Formal Match will be held in Pennsylvania, the U.S. on (date and time to be confirmed). The challenge flow is as follows:

1. The RMOC sets the participating sequence of teams based on the dates of their last submitted codes, and deploys their codes on officially modified RoboMaster EP robots.
2. The codes of each team will be deployed on-site, after which the competition is finished. The RMOC will announce the results on the designated platform, where teams can view their final scores from the match.
3. The RMOC will release the feedback data from the Referee System and robots as well as the match video on the designated platform for teams to download.
4. Each team may compare their final scores with the feedback data and match video released by the organizer, to verify their match results.

Table 5-1 Competition Flow

Item	Description
Setup period	competition area reset
Code Download	Launch Team’s code
Referee system initialization	Countdown initialization
Start of match	The calculation of points by the System
Match conclusion	Generating scores and confirming match results

6. Season Schedule

Table 6-1 Season Schedule

Date	Activities	Notes
February 15, 2022	Release of competition rules and relevant materials	RoboMaster official website
February 16, 2022 - February 28, 2022	Formal registration	RoboMaster official website
March 1, 2022 - March 30 2022	Simulator Test	Teams submit codes on the official website
March 31, 2022	Technical Assessment	Based on the ranking of simulator test 1. Qualified teams shortlisted 2. Double-confirming competition details
April 1, 2022 - May 15, 2022	Sim2Real Test	RMOC deploys each teams' submitted codes in physical environment, and provide feedback data and video respectively
May 20, 2022	Code submission	Each team is allowed to submit the codes only for once
ICRA 2022 Date: (to be confirmed)	Formal Match	Participating teams are not required to arrive on-site

The time of the Formal Match will be based on the local time zone of the competition venue, while the time of other matches is based on UTC+8 (Beijing time).

7. Participation

Participants are required to form teams and complete the application process on the registration page of the RoboMaster official website.

7.1 Participating Teams

1. Every team member is allowed to join only one team in a competition season.
2. Each team must have a minimum of one and maximum of five members. Each member’s roles and responsibilities must be detailed in the application form.
3. Every team must have one registered captain, who will be responsible for managing the team’s progress in the competition, liaising with the RMOC, and submitting competition reports, among other tasks.

7.2 Team Member

Table 7-1 Team Member’ roles and responsibilities

Roles	Role Instructions	No. of Persons	Status	Responsibilities
Supervisor	<ul style="list-style-type: none"> ● The main person in charge of the team, responsible for the formation and management of the team ● Responsible for communicating and liaising with the RMOC. ● Must not be an official team member. 	0-2	Faculty members of the team’s college or university who are qualified for teaching and scientific research during the period of October 2021 to June 2022	<ul style="list-style-type: none"> ● Responsible for the safety of team members and property, as well as instructing and managing the use of the team’s funds ● Instructs the team in developing their project plan and solving R&D issues, and helps the team complete the challenge successfully ● During the challenge, the supervisor must actively cooperate with the RMOC and ensure the captain reports to the RMOC regularly on the team’s progress and other matters

Roles	Role Instructions	No. of Persons	Status	Responsibilities
Regular members	<ul style="list-style-type: none"> Including the captain and general team members. Must not be a supervisor. 	1-5	With proof of full-time student identity up to September 2022	

Table 7-2 Roles and responsibilities of regular members

Roles	Role Instructions	No. of Persons	Responsibilities
Captain	<ul style="list-style-type: none"> Core team member, the team's technical and tactical leader The main liaison with the RMOC 	1	<ul style="list-style-type: none"> Responsible for the division of labor, overall planning and tactical arrangement and adjustment Attends the Captains Meeting, represents the team in confirming match results and participates in appeal processes and any subsequent hearings Responsible for passing on the team's expertise and the team's future development after the challenge
General Member	<ul style="list-style-type: none"> Including the captain and general team members. Must not be a supervisor. 	1-5	

7.3 Other Requirements

R1. Any team participating in different competitions must use the same team name. A team's name must be in the format of "XXX Team", where "XXX" shall be the team's self-chosen name. The total length of the self-chosen name should not exceed 16 English letters or 8 Chinese characters. The self-chosen name must not include the school name or its abbreviation in Chinese/English, or the word "team", "squad" and other equivalent terms in Chinese/English, or other special symbols such as "*/-+". The team name must reflect the positive and pioneering

spirit of the team and comply with relevant state laws and regulations. If the RMOC determines that a team’s name does not align with the spirit of the competition, it has the right to require the team to change its name.

R2. Each team must represent a university/college and meet the requirements for the roles, number and identity of members stated in “7.2 - Team Member”. If a team fails to meet the requirements, it may be disqualified from the competition.

R3. Each university/college is allowed to have more than one team participating in the competition. However, only the team with the highest score from each university/college in the simulator stage will advance to the next stage.

8. Awards

Table 8-1 Awards Setup

Prize	Ranking	Quantity	Awards
Grand Prize	First Place	1	<ul style="list-style-type: none"> ● Achievement Certificates (for each member) ● \$5,000 pre-tax
First Prize	Second Place	1	<ul style="list-style-type: none"> ● Achievement Certificates (for each member) ● \$3,000 pre-tax
	Third Place	1	<ul style="list-style-type: none"> ● Achievement Certificates (for each member) ● \$2,000 pre-tax
	Fourth Place	1	Achievement Certificates (for each member)
Second Prize	5-8	4	Achievement Certificates (for each member)

Prize	Ranking	Quantity	Awards
Third Prize	Teams that have passed the Technical Assessment but not advanced to Top 8.	(Several) To be determined based on the results of all teams	Achievement Certificates (for each member)
Participation Award	Teams that have submitted codes for simulation but not passed the Technical Assessment	(Several)	Achievement Certificates (for each member)

9. Appeals

9.1 Appeal Materials

How to appeal: Save the edited video (contents of which to be prepared by the team) and the text files containing the appeal materials in a folder (its total size not exceeding 100MB), and send it to the arbitration staff.

Material format: No video may exceed one minute in length. The name of the video must indicate the specific match, the round of the match and the time it was taken (rounded to minutes). The videos should be compatible with the latest version of Windows Media Player; the photos must be in JPG format; and the text documents must be in PDF format and not exceed 1,000 characters in length.

Naming of materials: The file name of each video and photo must be within 30 characters.

Text requirements: One text file can only correspond to one video or a photo, which must be indicated in the text. Only the violations reflected in the corresponding materials need to be addressed in the text files.

9.2 Appeal Process

Teams lodging an appeal must follow the procedure below:

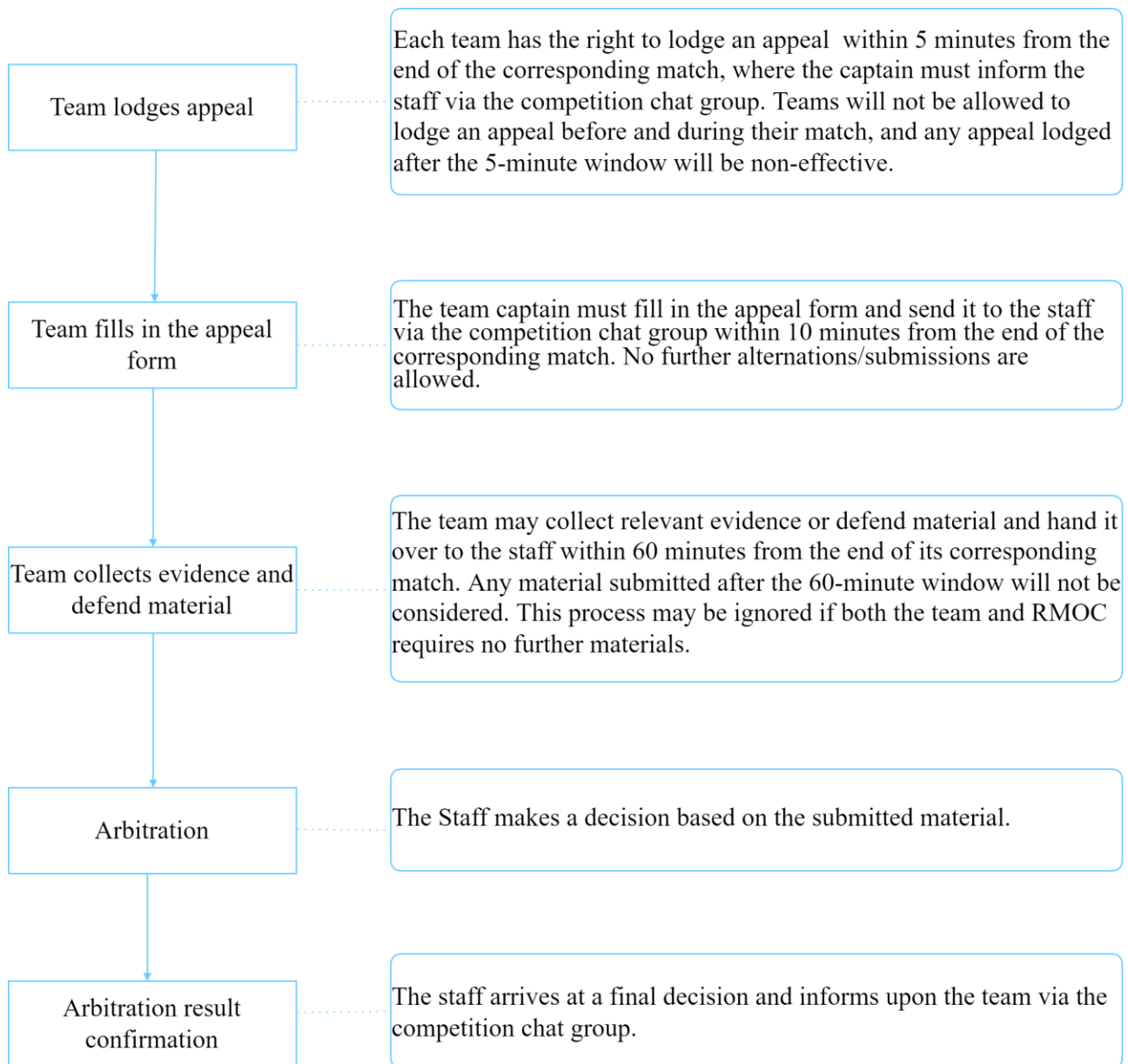

9.3 Appeal Decision

The arbitration decisions that can be made include: Maintaining the original match results or ordering a rematch. Teams may not appeal against the decision made by the Arbitration Commission.

If a rematch is required by an arbitration decision, the RMOC will inform the teams of the time of the rematch when announcing the decision. If the team refuses the rematch, the appeal is deemed failed and the original match results are maintained.

10. Q&A

After the start of the competition season, the RMOC will set up an official chat group in which it will conduct online Q&A sessions and upload frequently asked questions in the competition onto the group’s “Q&A Files”.



E-mail: robomaster@dji.com

Forum: bbs.robomaster.com

Website: www.robomaster.com

Tel: +86 (0)755 36383255 (GTC+8, 10:30AM-7:30PM, Monday to Friday)

Address: Room 202, Floor 2, Integrated Circuit Design & Application Industrial Park, No. 1089,
Chaguang Road, Xili County, Nanshan District, Shenzhen City, Guangdong Province, China